

威峻傳動國際有限公司

WEI JUN MOTION INTERNATIONAL CO., LTD.



FA 自動化零件組 一站式採購平台



線性導軌
Linear Guideway

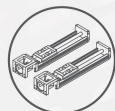

單軸機器人
Single Axis Robot



公司簡介與理念

威峻傳動國際王進平總經理，一直以來皆秉持著四大核心理念「誠信」、「服務」、「品質」與「效率」，對內教育員工、對外行銷品牌。王總經理在桃園深耕五十年，以豐富的業務經驗及專業知識帶領著團隊，客群拓展從北部至全國，從台灣至北美洲、東南亞、紐西蘭、中國大陸等地區，持續提供機械業界精良的產品品質與完善的售後服務。隨著尖端科技產業的快速成長與眾多客戶的支持，我司得以站穩腳步，並盼望能成為客戶心中最佳的夥伴，共創商機，相互成長及永續經營，期待與您攜手努力共創未來。

專業經銷

我司榮幸受各國際品牌信任，紛紛獲得經銷代理權。榮獲日本 **Koyo** 軸承全台十大經銷商之一。同時於 2024 年與國際大廠 **ABBA** 原研發團隊共同創立 **TWJB** 線性導軌，滾珠螺桿且獲得獨家經營權。另專業銷售 **WJB** 直線軸承、精密軸心、線性伺服滑台、螺桿支撐座、銅自潤軸承、萬向滾珠、不鏽鋼軸承、工程塑膠軸承、聯軸器、免鍵式襯套等產品，一站式採購平台滿足廣大客戶不同需求。

業務團隊

威峻業務團隊擁有專業、熱誠、耐心、積極、樂觀、將心比心的服務態度。替客戶解決疑難雜症，將客戶的問題當作是自己的問題，以快速、實際的方式為您排除，是一群值得放心的菁英業務團隊。





後勤團隊

專業的工程師，對於線性滑軌、滾珠螺桿，要求預壓等級分類，可快速處理，節省時間，增加客戶的生產力。另我司配有多輛公用物流車並與多間現代化高品質物流公司配合，以達成貨品快速的交遞。

Professional Supplier Of Linear Motion Products

庫存齊全

產品庫存豐富，各式軸承、傳動零件組，品項數萬種。鍍鉻軸心、線性滑軌和滾珠螺桿等現貨供應，下單即可當日裁切，提升效率，在最短的時間內滿足客戶的急件需求。



專業技術 支持

WJB 的產品開發過程，
皆經過嚴謹的測試，力求將
最優秀的產品提供給客戶。

WJB
MOTION

WJB



● 大理石線軌磨床設備



● 滑塊加工機



● 高週波熱處機



● 德國旋銑磨床機



● 滑塊自動組裝機



● 輪廓檢測儀

線性導軌

Linear Guideway

▶ TWJB 線性傳動
TWJB linera transmission

全程品質把控，可靠的表面熱處理工藝，多次精密研磨，多形位跳動檢測



線性導軌

TWJB 線性傳動

TWJB linera transmission

(1)非互換性線性導軌產品型號

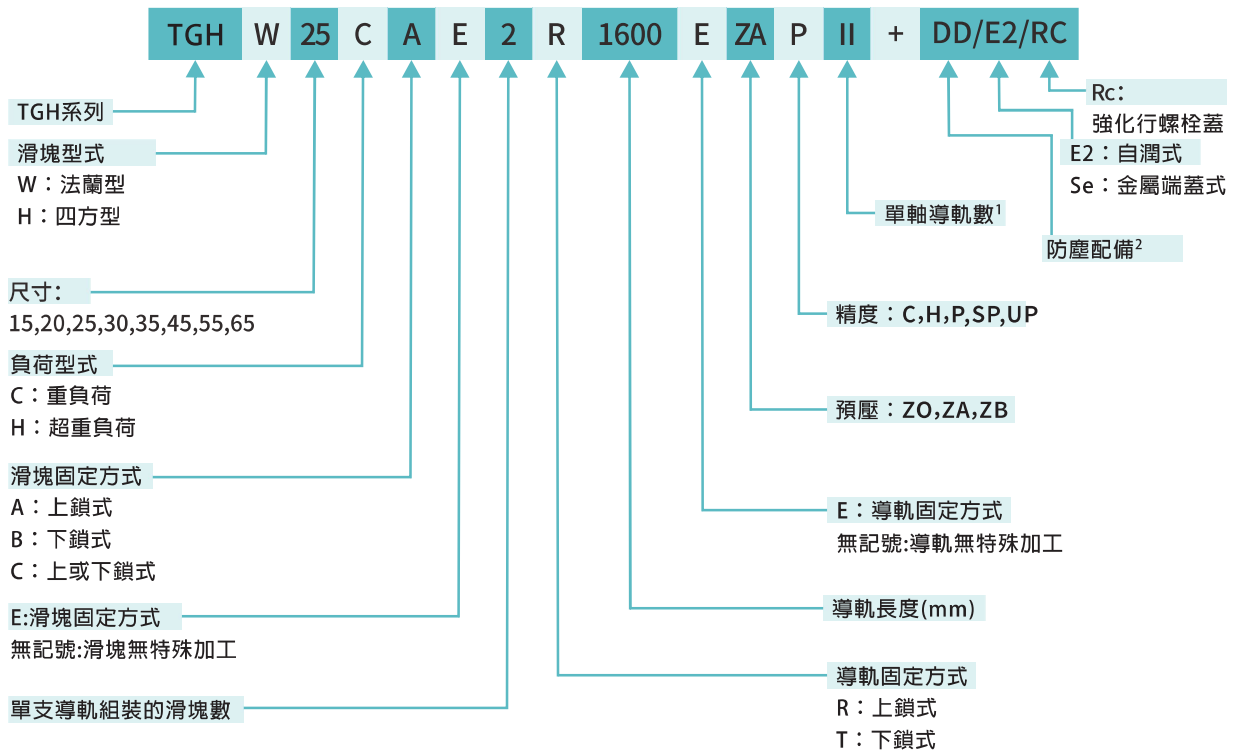

(2)互換性線性導軌產品型號

◎互換型滑塊產品型號

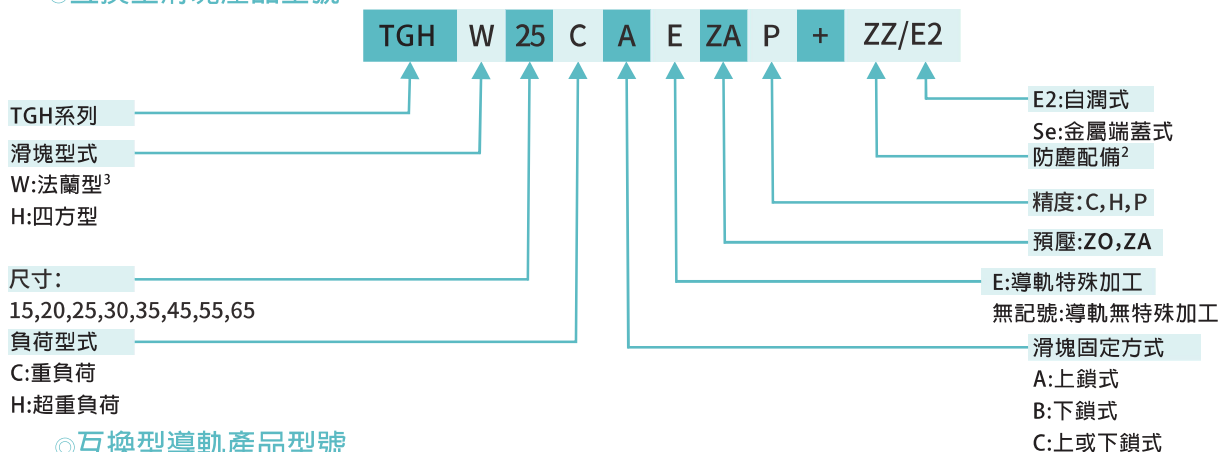

◎互換型導軌產品型號

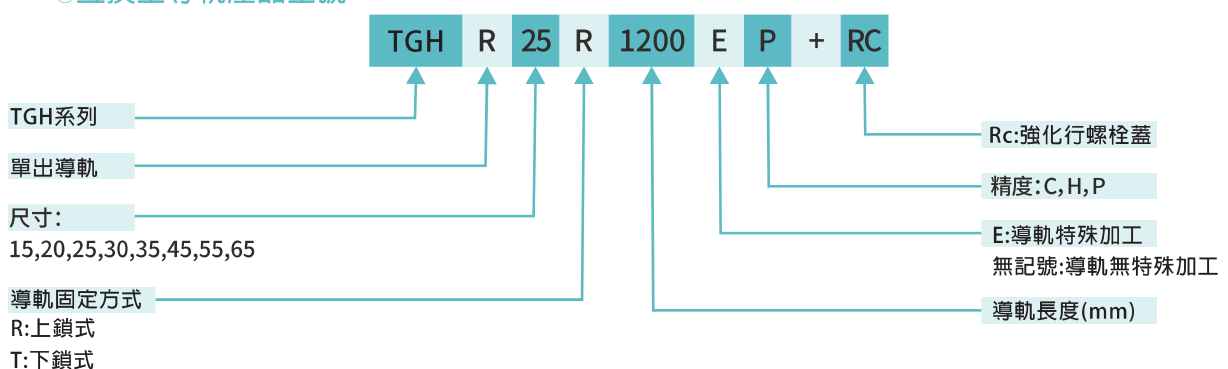

▶ TWJB 線性傳動
TWJB linera transmission

TGH 系列重負荷方型滾珠線性導軌
TGH series heavy load ball linear guide

(1)TGHH-CA/TGHH-HA

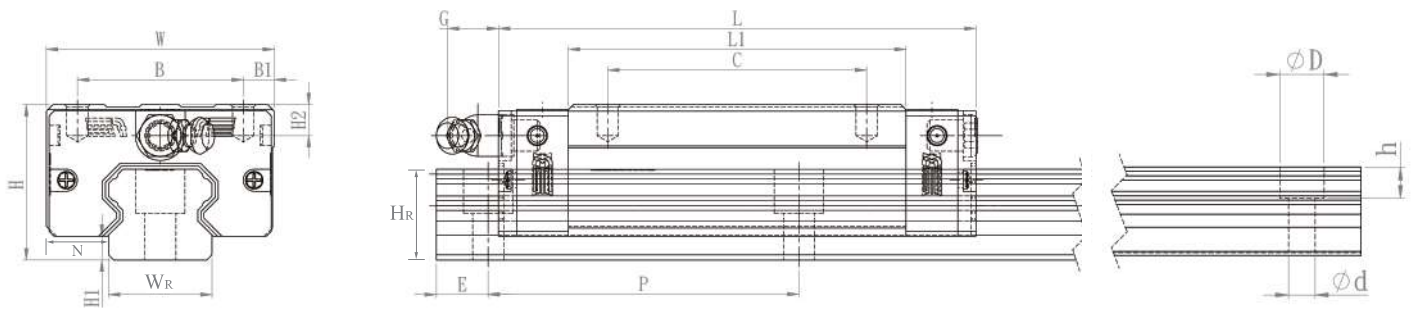

型號	組件尺寸 (mm)			滑塊尺寸 (mm)							導軌尺寸 (mm)							導軌的固定螺栓尺寸 (mm)	基本動額定負荷 C (kN)	基本靜額定負荷 Co (kN)	容許靜力矩			重量			
	H	H ₁	N	W	B	B ₁	C	L ₁	L	G	MxL	H ₂	W _R	H _R	D	h	d				P	E	M _R	M _P	M _V	滑塊	導軌
	mm	mm	mm	mm	mm	mm	mm	mm	mm	mm	mm	mm	mm	mm	mm	mm	mm				mm	mm	kN-m	kN-m	kN-m	kg	kg/m
TGHH15CA	28	4.3	9.5	34	26	4	26	39.7	59.4	5.3	M4x5	8	15	15	7.5	5.3	4.5	60		M4x16	14.0	22.30	0.12	0.10	0.10	0.18	1.45
TGHH20CA	30	4.6	12	44	32	6	36	50.7	75.2	12	M5x6	6	20	17.5	9.5	8.5	6	60		M5x16	25.7	34.85	0.27	0.20	0.20	0.30	2.21
TGHH20HA							50	65.3	90												31.1	45.56	0.35	0.35	0.35	0.39	
TGHH25CA	40	5.5	12.5	48	35	6.5	35	58.2	82	12	M6x8	10	23	22	11	9	7	60		M6x20	33.2	50.18	0.42	0.33	0.33	0.51	3.21
TGHH25HA							50	78.8	102.5												40.1	65.62	0.56	0.57	0.57	0.69	
TGHH30CA	45	6	16	60	40	10	40	69.7	94.5	12	M8x10	9.5	28	26	14	12	9	80		M8x25	46.1	68.28	0.66	0.53	0.53	0.88	4.47
TGHH30HA							60	92	116.7												55.7	89.29	0.88	0.92	0.92	1.16	
TGHH35CA	55	7.5	18	70	50	10	50	79.2	109.5	12	M8x12	15.6	34	29	14	12	9	80		M8x25	61.4	89.19	1.16	0.81	0.81	1.45	6.30
TGHH35HA							72	104.6	135												74	116.63	1.54	1.40	1.40	1.92	
TGHH45CA	70	9.5	20.5	86	60	13	60	97	134	12.9	M10x17	18.5	45	38	20	17	14	105		M12x35	98.6	139.37	1.98	1.55	1.55	2.73	10.41
TGHH45HA							80	128.5	165.4												119	182.26	2.63	2.68	2.68	3.61	
TGHH55CA	80	13	23.5	100	75	12.5	75	119.6	162	12.9	M12x18	21.4	53	44	23	20	16	120		M14x45	145.5	200.67	3.69	2.64	2.64	4.17	15.08
TGHH55HA							95	157.9	200.6												175.7	262.42	4.88	4.57	4.57	5.49	
TGHH65CA	90	15	31.5	126	76	25	70	144.2	198.3	12.9	M16x20	15	63	53	26	22	18	150		M16x50	202.5	273.11	6.65	4.27	4.27	7.00	21.18
TGHH65HA							120	199.7	250												263.9	399.16	9.38	7.38	7.38	9.82	

注: 1kgf = 9.81N

▶ TWJB 線性傳動

TWJB linera transmission

TGH 系列重負荷法蘭型滾珠線性導軌

TGH series heavy load ball linear guide

(5) TGHW-CC/TGW-HC

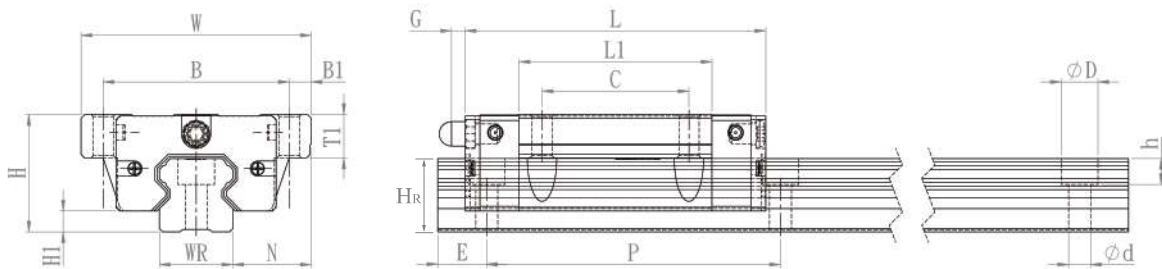

型號	組件尺寸 (mm)			滑塊尺寸 (mm)							導軌尺寸 (mm)							導軌的固定螺柱尺寸 (mm)	基本動額定負荷 C (kN)	基本靜額定負荷 C ₀ (kN)	容許靜力矩			重量			
	H	H ₁	N	W	B	B ₁	C	L ₁	L	G	M	T ₁	W _R	H _R	D	h	d				P	E	M _r kN-m	M _p kN-m	M _v kN-m	滑塊 kg	導軌 kg/m
TGHW15CC	24	4.3	16	47	38	4.5	30	39.7	59.4	5.3	M5	8.9	15	15	7.5	5.3	4.5	60		M4x16	14.0	22.30	0.12	0.10	0.10	0.17	1.45
TGHW20CC	30	4.6	21.5	63	53	5	40	50.7	75.2	12	M6	10	20	17.5	9.5	8.5	6	60		M5x16	25.7	34.85	0.27	0.20	0.20	0.40	2.21
TGHW20HC								65.3	90												31.1	45.56	0.35	0.35	0.35		
TGHW25CC	36	5.5	23.5	70	57	6.5	45	58.2	82	12	M8	14	23	22	11	9	7	60		M6x20	33.2	50.18	0.42	0.33	0.33	0.59	3.21
TGHW25HC								78.8	102.5												40.1	65.62	0.56	0.57	0.57	0.80	
TGHW30CC	42	6	31	90	72	9	52	69.7	94.5	12	M10	16	28	26	14	12	9	80		M8x25	46.1	68.28	0.66	0.53	0.53	1.09	4.47
TGHW30HC								92	116.7												55.7	89.29	0.88	0.92	0.92	1.44	
TGHW35CC	48	7.5	33	100	82	9	62	79.2	109.5	12	M10	17.7	34	29	14	12	9	80		M8x25	61.4	89.19	1.16	0.81	0.81	1.56	6.30
TGHW35HC								104.6	135												74.0	116.63	1.54	1.40	1.40	2.06	
TGHW45CC	60	9.5	37.5	120	100	10	80	97	134	12.9	M12	22	45	38	20	17	14	105		M12x35	98.6	139.37	1.98	1.55	1.55	2.79	10.41
TGHW45HC								128.5	165.4												119.0	182.26	2.63	2.68	2.68	3.69	
TGHW55CC	70	13	43.5	140	116	12	95	119.6	162	12.9	M14	26.5	53	44	23	20	16	120		M14x45	145.5	200.67	3.69	2.64	2.64	4.52	15.08
TGHW55HC								157.9	200.6												175.7	262.42	4.88	4.57	4.57	5.96	
TGHW65CC	90	15	53.5	170	142	14	110	144.1	198.3	12.9	M16	37.5	63	53	26	22	18	150		M16x50	202.5	273.11	6.65	4.27	4.27	9.17	21.18
TGHW65HC								199.7	250												263.9	399.16	9.38	7.38	7.38	12.89	

注: 1kgf=9.81N

▶ TWJB 線性傳動
TWJB linera transmission

(1)非互換性線性導軌產品型號

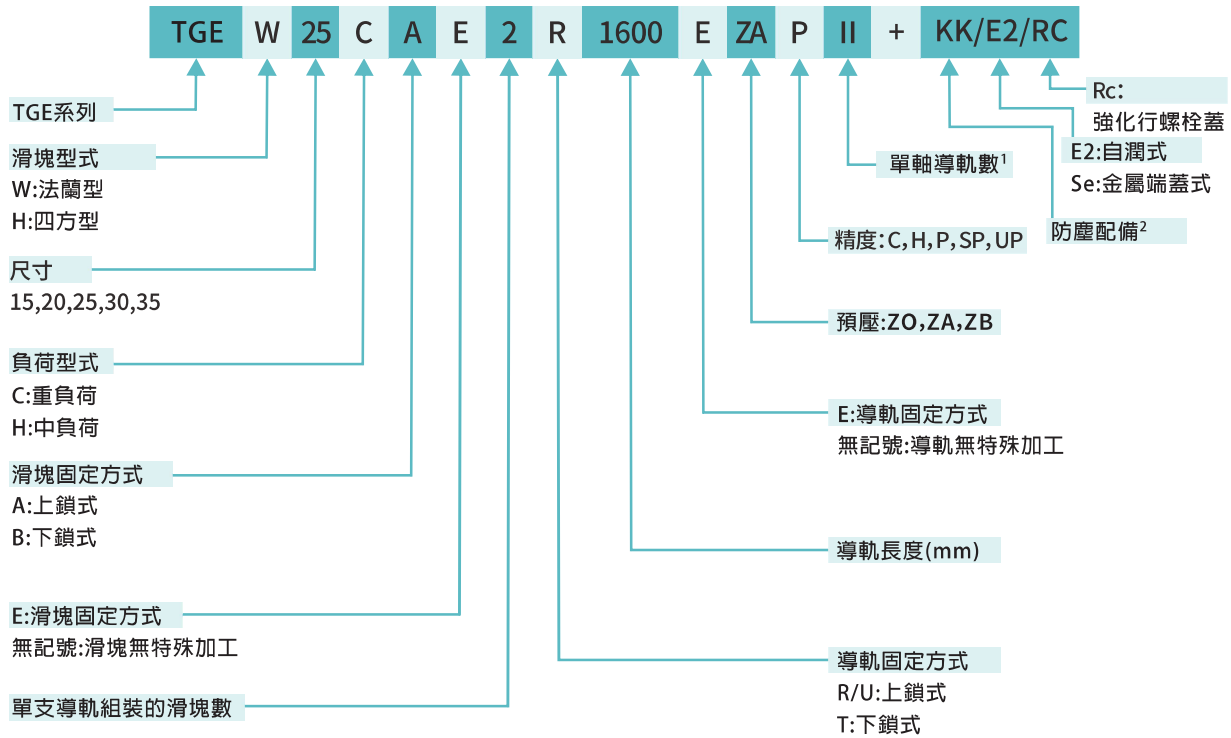

(2)互換性線性導軌產品型號

◎互換型滑塊產品型號

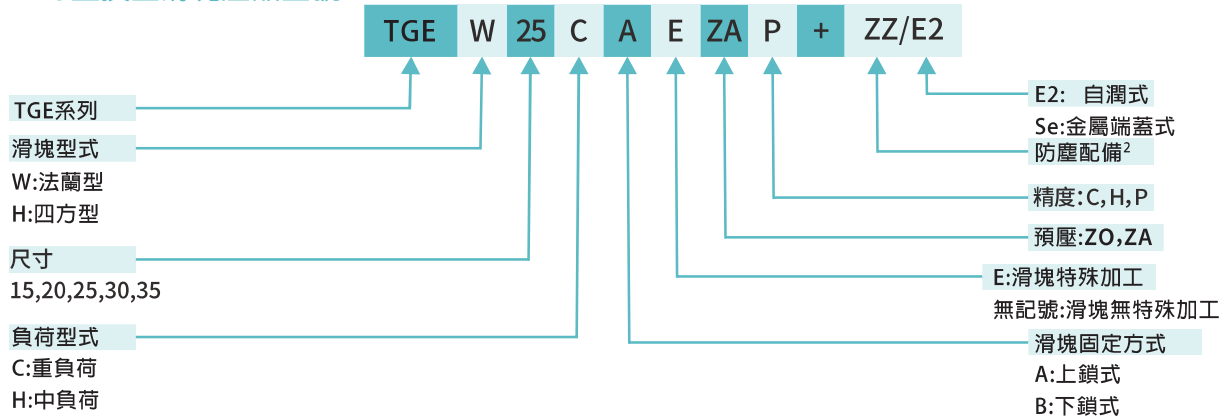

◎互換型導軌產品型號

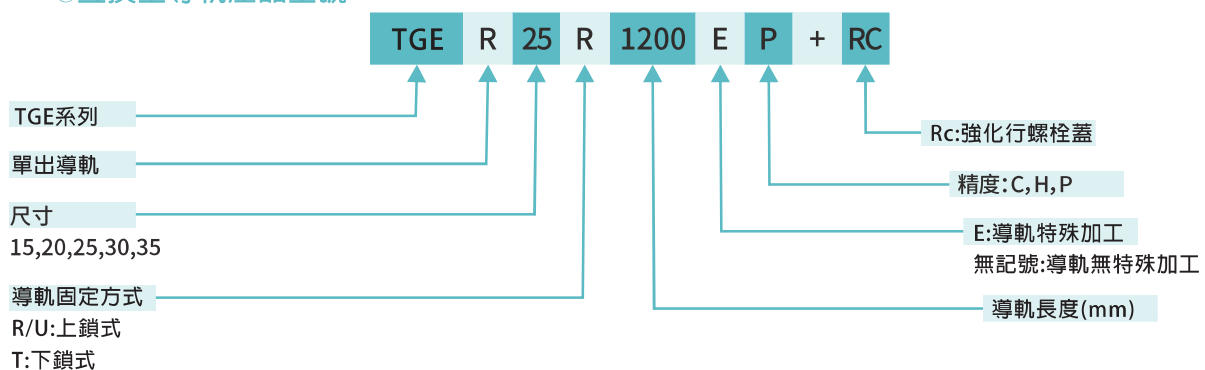

TWJB 線性傳動

TWJB linera transmission

TGE 系列低組裝方型滾珠線性導軌 TGE series low assembly ball linear guide

TGE系列線性導軌尺寸表

(1)TGEH-SA/TGEH-CA

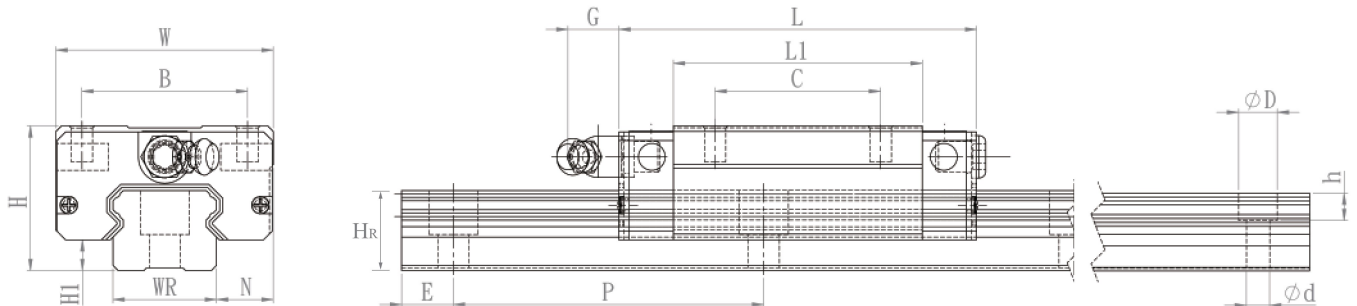

型號	組件尺寸 (mm)				滑塊尺寸 (mm)				導軌尺寸 (mm)						導軌的固定螺柱尺寸 (mm)	基本動額定負荷 C (kN)	基本靜額定負荷 C ₀ (kN)	容許靜力矩			重量				
	H	H ₁	N	W	B	C	L ₁	L	G	MxL	W _R	H _R	D	h				d	P	E	M _R	M _P	M _V	滑塊	導軌
																		kN-m	kN-m	kN-m	kg	kg/m			
TGEH15SA	24	4.5	9.5	34	26	-	23.2	39.7	5.7	M4x6	15	12.5	7.5	5.3	4.5	60		M4x16	4.82	8.46	0.08	0.04	0.04	0.09	1.25
TGEH15CA						26	39.9	56.8											7.05	14.57	0.13	0.10	0.10	0.15	
TGEH20SA	28	6	11	42	32	-	29	50.1	12	M5x7	20	15.5	9.5	8.5	6	60		M5x16	6.51	11.47	0.13	0.06	0.06	0.15	2.08
TGEH20CA						32	48.2	70.7											9.28	19.02	0.22	0.16	0.16	0.24	
TGEH25SA	33	7	12.5	48	35	-	35.6	60.4	12	M6x9	23	18	11	9	7	60		M6x20	10.26	17.55	0.23	0.12	0.12	0.25	2.67
TGEH25CA						35	59.2	82.6											14.64	29.16	0.38	0.32	0.32	0.41	
TGEH30SA	42	10	16	60	40	-	41.5	69.2	12	M8x12	28	23	14	12	9	80		M8x25	14.78	25.29	0.40	0.21	0.21	0.45	4.35
TGEH30CA						40	70.3	97.9											21.33	42.71	0.68	0.55	0.55	0.76	
TGEH35SA	48	11	18	70	50	-	45	75	12	M8x12	34	27.5	14	12	9	80		M8x25	20.39	33.63	0.56	0.31	0.31	0.74	6.14
TGEH35CA						50	78.5	109.4											30.02	58.36	0.98	0.69	0.69	1.10	

注: 1kgf=9.81N

TGE 系列低組裝法蘭型滾珠線性導軌

TGE series low assembly ball linear guide

(2) TGEW-SA/TGEW-CA

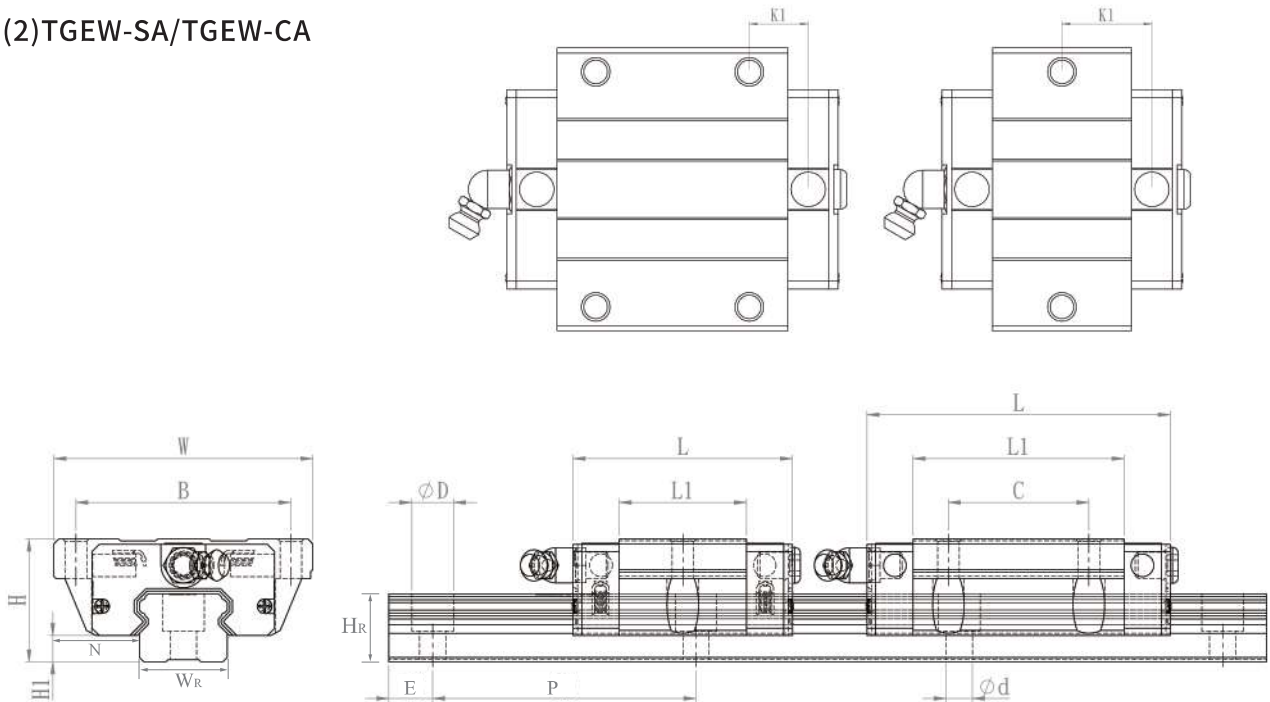

型號	組件尺寸 (mm)					滑塊尺寸 (mm)					導軌尺寸 (mm)						導軌的固定螺栓尺寸 (mm)	基本動額定負荷 C (kN)	基本靜額定負荷 C ₀ (kN)	容許靜力矩			重量		
	H	H ₁	N	W	B	C	L ₁	L	K ₁	M	W _R	H _R	D	h	d	P				E	M _R kN-m	M _P kN-m	M _V kN-m	滑塊 kg	導軌 kg/m
TGEW15SA	24	4.5	18.5	52	41	-	23.2	39.7	14.8	M5	15	12.5	7.5	5.3	4.5	60		M4x16	4.82	8.46	0.08	0.04	0.04	0.12	1.25
TGEW15CA						26	39.9	56.8	10.15										7.05	14.57	0.13	0.10	0.10	0.21	
TGEW20SA	28	6	19.5	59	49	-	29	50.1	18.8	M6	20	15.5	9.5	8.5	6	60		M5x16	6.51	11.47	0.13	0.06	0.06	0.19	2.08
TGEW20CA						32	48.2	70.7	12.3										9.28	19.02	0.22	0.16	0.16	0.32	
TGEW25SA	33	7	25	73	60	-	35.6	60.4	21.9	M8	23	18	11	9	7	60		M6x20	10.26	17.55	0.23	0.12	0.12	0.35	2.67
TGEW25CA						35	59.2	82.6	16.3										14.64	29.16	0.38	0.32	0.32	0.59	
TGEW30SA	42	10	31	90	72	-	41.5	69.2	25.8	M10	28	23	14	12	9	80		M8x25	14.78	25.29	0.40	0.21	0.21	0.62	4.35
TGEW30CA						40	70.3	97.9	20.1										21.33	42.71	0.68	0.55	0.55	1.04	
TGEW35SA	48	11	33	100	82	-	45	75	28.5	M10	34	27.5	14	12	9	80		M8x25	20.39	33.64	0.56	0.31	0.31	0.84	6.14
TGEW35CA						50	78.5	109.4	20										30.02	58.36	0.98	0.69	0.69	1.45	

注: 1kgf=9.81N

TWJB 線性傳動

TWJB linera transmission

TGM 系列微型滾珠線性導軌

TGH series miniature ball linear guide

(1) 非互換性線性導軌產品型號

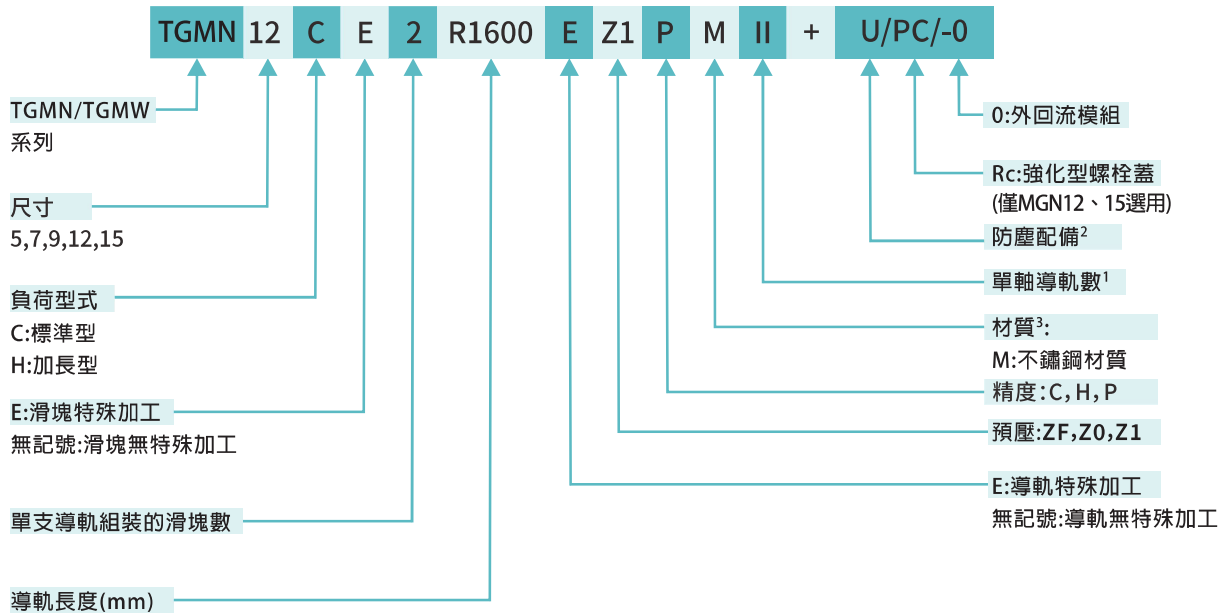

(2) 互換性線性導軌產品型號

◎單出滑塊產品型號

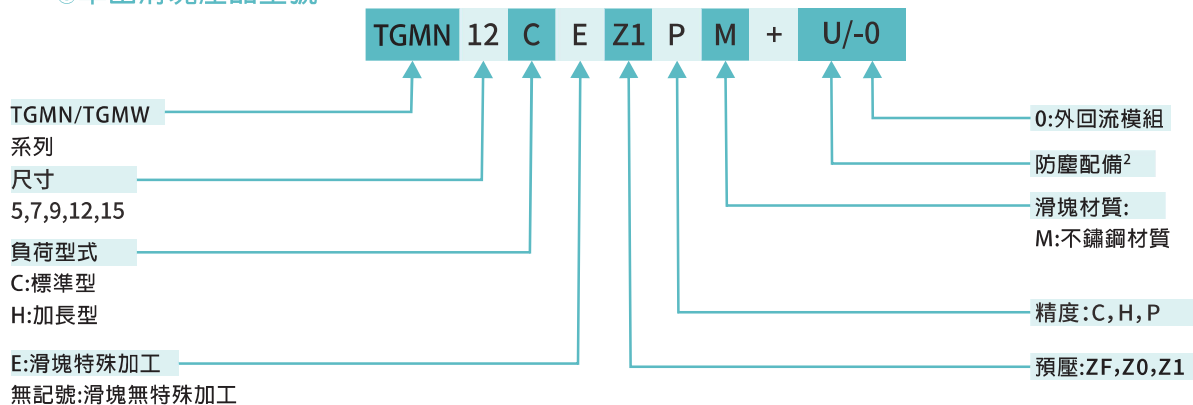

▶ TWJB 線性傳動
TWJB linera transmission

TGM 系列微型滾珠線性導軌
TGH series miniature ball linear guide

(1)TGMN-C/TGMN-H

TGMN7,TGMN9,TGMN12,TGMN15

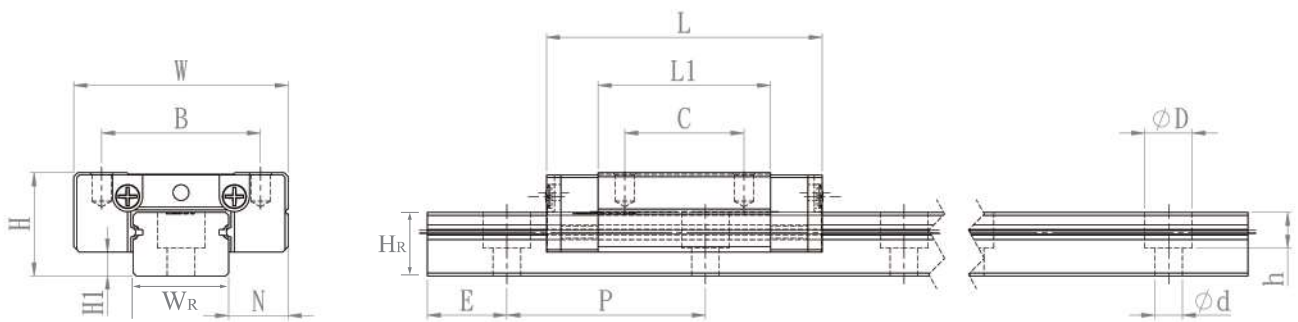

型號	組件尺寸 (mm)				滑塊尺寸 (mm)				導軌尺寸 (mm)						導軌的固定螺柱尺寸 (mm)	基本動額定負荷 C (kN)	基本靜額定負荷 Co (kN)	容許靜力矩			重量		
	H	H ₁	N	W	B	C	L ₁	L	MxI	W _R	H _R	D	h	d				P	E	M _r kN-m	M _p kN-m	M _v kN-m	滑塊 kg
TGMN7C	8	1.5	5	17	12	8	13.5	22.5	M2x2.5	7	4.8	4.2	2.3	2.4	15	M2x6	0.93	1.18	4.70	2.84	2.84	0.010	0.22
TGMN7H						13	21.8	30.8									1.30	1.86	7.64	4.80	4.80	0.015	
TGMN9C	10	2	5.5	20	15	10	18.9	28.9	M3x3	9	6.5	6	3.5	3.5	20	M3x8	1.77	2.42	11.76	7.35	7.35	0.016	0.38
TGMN9H						16	29.9	39.9									2.42	3.81	19.60	18.62	18.62	0.026	
TGMN12C	13	3	7.5	27	20	15	21.7	34.7	M3x3.5	12	8	6	4.5	3.5	25	M3x8	2.70	3.72	25.48	13.72	13.72	0.034	0.65
TGMN12H						20	32.4	45.4									3.53	5.59	38.22	36.26	36.26	0.054	
TGMN15C	16	4	8.5	32	25	20	26.7	42.1	M3x4	15	10	6	4.5	3.5	40	M3x10	4.38	5.31	45.08	21.56	21.56	0.059	1.06
TGMN15H						25	43.4	58.8									6.05	8.65	73.50	57.82	57.82	0.092	

注: 1kgf=9.81N

TWJB 線性傳動

TWJB linera transmission

TGM 系列微型滾珠線性導軌(寬版型)

TGH series miniature ball linear guide

(2)TGMW-C/TGMW-H

TGMW7,TGMW9,TGMW12

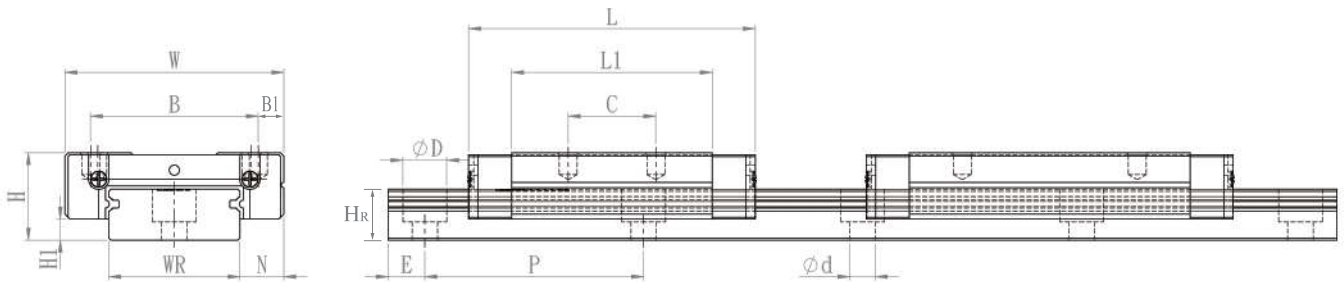

TGMW15

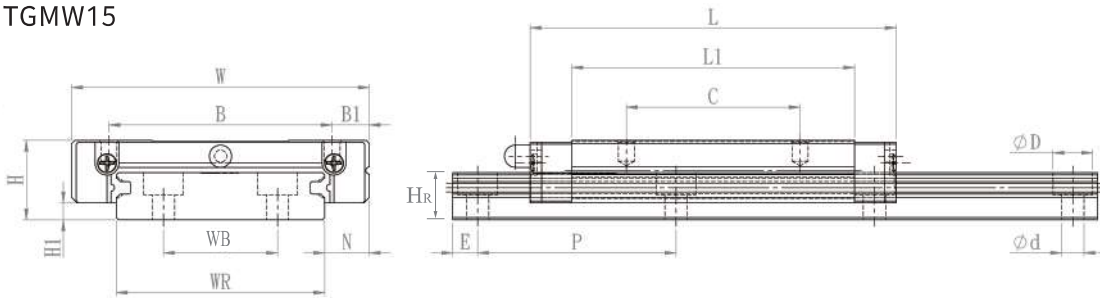

型號	組件尺寸 (mm)			滑塊尺寸 (mm)							導軌尺寸 (mm)							導軌的固定螺栓尺寸 (mm)	基本動額定負荷 C (kN)	基本靜額定負荷 C ₀ (kN)	容許靜力矩			重量		
	H	H ₁	N	W	B	B ₁	C	L ₁	L	MxI	W _R	W _B	H _R	D	h	d	P				E	M _r kN-m	M _p kN-m	M _v kN-m	滑塊 kg	導軌 kg/m
TGMW7C	9	1.9	5.5	25	19	3	10	21	31.2	M3x3	14	-	5.2	6	3.2	3.5	30		M3x6	1.30	1.96	15.70	7.14	7.14	0.020	0.51
TGMW7H							19	30.8	41											2.61	3.91	40.12	18.96	18.96	0.040	
TGMW9C	12	2.9	6	30	21	4.5	12	27.5	39.3	M3x3	18	-	7	6	4.5	3.5	30		M3x8	2.61	3.91	40.12	18.96	18.96	0.040	0.91
TGMW9H							23	3.5	24											38.5	50.7	3.26	5.60	54.54	34.00	
TGMW12C	14	3.4	8	40	28	6	15	31.3	46.1	M3x3.6	24	-	8.5	8	4.5	4.5	40		M4x8	3.72	5.31	70.34	27.80	27.80	0.071	1.49
TGMW12H							28	45.6	60.4											4.85	7.83	102.70	57.37	57.37	0.103	
TGMW15C	16	3.4	9	60	45	7.5	20	38	54.8	M4x4.2	42	23	9.5	8	4.5	4.5	40		M4x10	6.43	8.76	199.34	56.66	56.66	0.143	2.86
TGMW15H							35	57	73.8											8.48	12.71	299.01	122.60	122.60	0.215	

注:1kgf=9.81N

單軸機器人

Single Axis Robot

▶ TWJB 線性傳動
TWJB linera transmission



單軸機器人

TKK單軸機器人主要是透過模組化之設計,將滾珠螺絲和線性導軌整合在一起,因此可提供具有高精度、快速安裝、選用、高剛性、體積小節省空間等特性藉由高精度之滾珠螺絲做為傳動機構,以及配合優化設計之U型軌道做為導引機構,來確保精度與剛性之需求。

特性：顧客成本花費削減，安裝與維護容易，節省安裝空間，防塵設計，高鋼性高精度，高效率，高可靠性。

應用：高精準產業、半導體產業、醫療檢測或試驗環境自動化產業、FPD面板搬運、檢測或試驗環境。

▶ TWJB 線性傳動

TWJB linera transmission

TKK型單軸機器人 TKK type single axis robot

產品型號

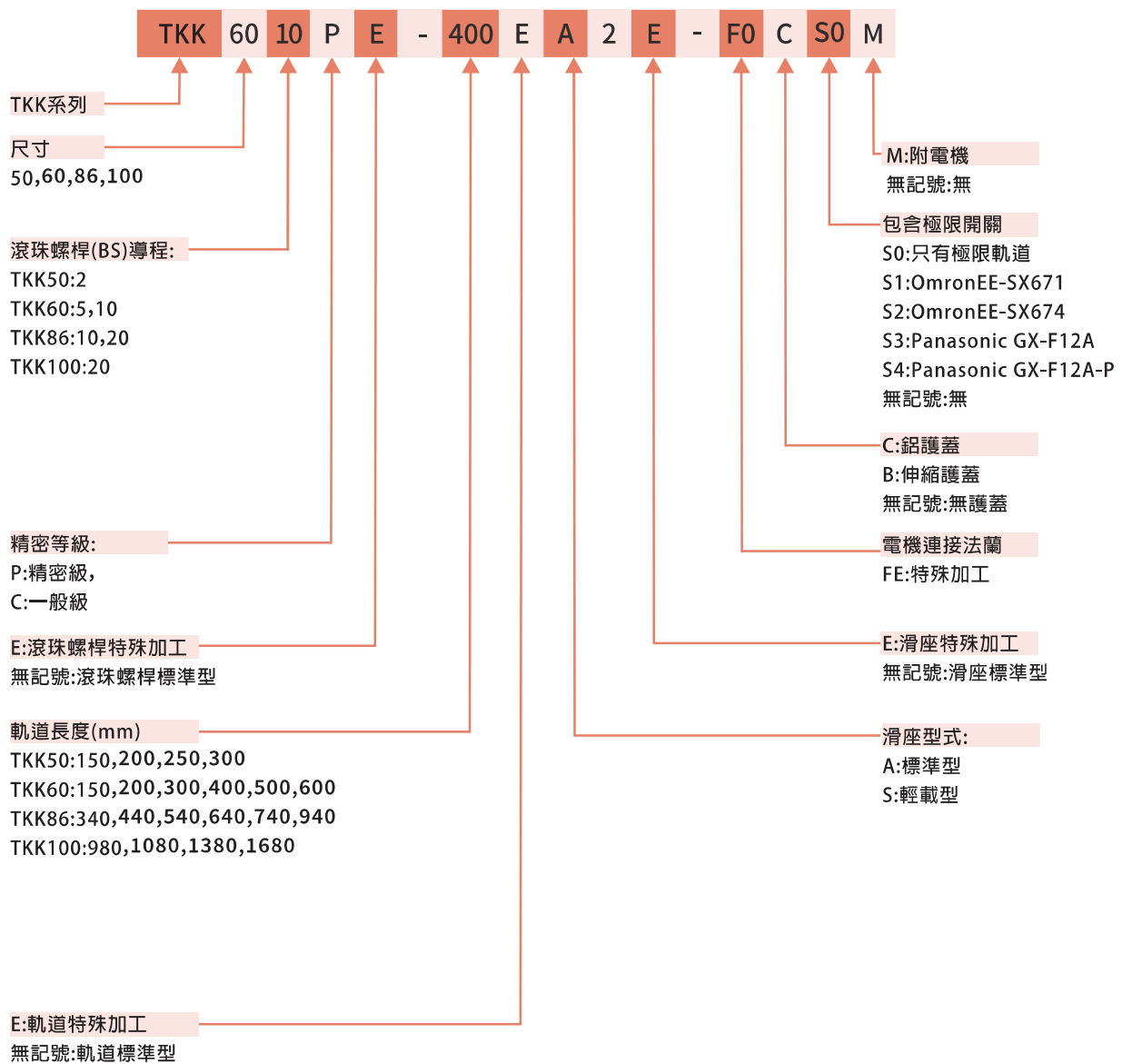

**Professional Supplier
Of Linear Motion
Products**



高標準. 高性能. 高品質



威峻傳動國際有限公司

🏠 桃園市蘆竹區中興二街28號(中興工業區)
☎ 03-3235599 📠 03-3136966
🌐 www.wjbmotion.com
✉ wjgogo@yahoo.com.tw

WEI JUN MOTION INTERNATIONAL CO., LTD.

🏠 NO.28, ZHONGXING 2ND ST., LUZHU DIST.,
TAOYUAN CITY 33857, TAIWAN (R.O.C.)
☎ +886-3-3235599 📠 +886-3-3136966
🌐 www.wjbmotion.com
✉ wjbrobot@gmail.com

