

## ■ BK 系列 / 方形固定側

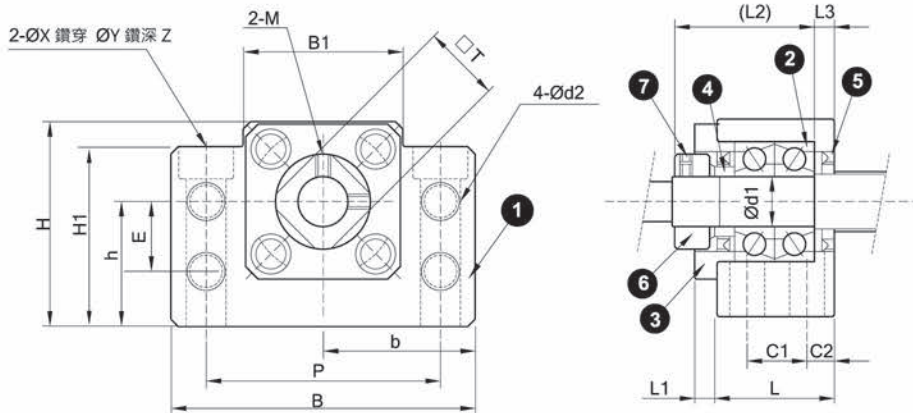

編號 Part No.	部品名稱 Part name	數量 Qty
1	軸承座主體	1
2	軸承	1 組
3	壓板	1
4	間隔圈	2
5	軸封	2
6	鎖固螺帽	1 組
7	內六角止付螺絲附銅片	2

單位/Unit : mm

型號	d1	L	L1	L2	L3	B	H	b		h	B1	H1	E	P	C1	C2	d2	X	Y	Z	M	T
								+0.02	+0.02													
BK10	10	25	5	29	5	60	39	30	22	34	32.5	15	46	13	6	5.5	6.6	10.8	5	M3	16	
BK12	12	25	5	29	5	60	43	30	25	34	32.5	18	46	13	6	5.5	6.6	10.8	1.5	M4	19	
BK15	15	27	6	32	6	70	48	35	28	40	38	18	54	15	6	5.5	6.6	11	6.5	M4	22	
BK17	17	35	9	44	7	86	64	43	39	50	55	28	68	19	8	6.6	9	14	8.5	M4	24	
BK20	20	35	8	43	8	88	60	44	34	52	50	22	70	19	8	6.6	9	14	8.5	M4	30	
BK25	25	42	12	54	9	106	80	53	48	64	70	33	85	22	10	9	11	17.5	11	M5	35	
BK30	30	45	14	61	9	128	89	64	51	76	78	33	102	23	11	11	14	20	13	M6	40	
BK35	35	50	14	67	12	140	96	70	52	88	79	35	114	26	12	11	14	20	13	M8	50	
BK40	40	61	18	76	15	160	110	80	60	100	90	37	130	33	14	14	18	26	17.5	M8	50	

## ■ BF 系列 / 方形支撐側

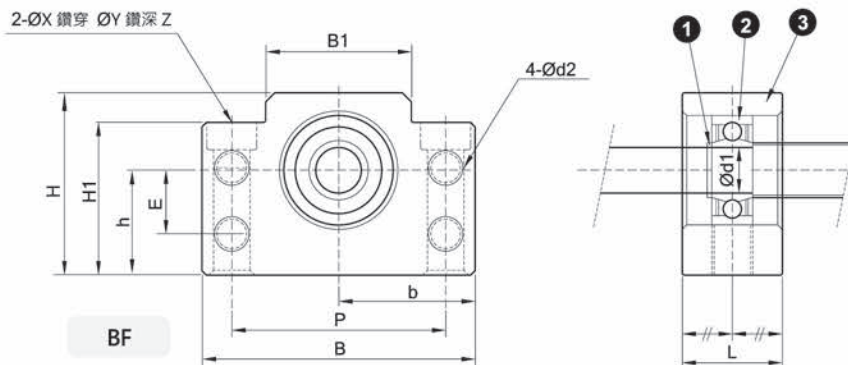

編號 Part No.	部品名稱 Part name	數量 Qty
1	軸承座主體	1
2	軸承	1 組
3	C型扣環	1

單位/Unit : mm

型號	d1	L	B	H	b		h	B1	H1	E	P	d2	X	Y	Z	使用軸承	使用C型扣環
					+0.02	+0.02											
BF10	8	20	60	39	30	22	34	32.5	15	46	5.5	6.6	10.8	5	608ZZ	S 08	
BF12	10	20	60	43	30	25	34	32.5	18	46	5.5	6.6	10.8	1.5	6000ZZ	S 10	
BF15	15	20	70	48	35	28	40	38	18	54	5.5	6.6	11	6.5	6002ZZ	S 15	
BF17	17	23	86	64	43	39	50	55	28	68	6.6	9	14	8.5	6203ZZ	S 17	
BF20	20	26	88	60	44	34	52	50	22	70	6.6	9	14	8.5	6004ZZ	S 20	
BF25	25	30	106	80	53	48	64	70	33	85	9	11	17.5	11	6205ZZ	S 25	
BF30	30	32	128	89	64	51	76	78	33	102	11	14	20	13	6206ZZ	S 30	
BF35	35	32	140	96	70	52	88	79	35	114	11	14	20	13	6207ZZ	S 35	
BF40	40	37	160	110	80	60	100	90	37	130	14	18	26	17.5	6208ZZ	S 40	